

Parameters

Electrical Parameters:	
Working voltage	DC5V (from wireless power interface)
Power consumption	40mA/DC5V (HDL-MPT1-RF.16)
	42mA/DC5V (HDL-MPT2-RF.16)
	45mA/DC5V(HDL-MPT4-RF.16)
	50 mA/DC5V(HDL-MPT6-RF.16)
Indoor communication distance	30m(Barrier free)
RSSI received signal strength intensity	>-80dbm
Factory frequency	Band, PSK (Suggestion: your setting should not be same as the factory setting)

Environmental Conditions:	
Working temperature	-5°C~45°C
Working relative humidity	Up to 90%
Storage temperature	-20°C~+60°C
Storage relative humidity	Up to 93%

Approved	
CE	
RoHS	

Product Information:	
Dimensions	86×116×10.5 (mm)
Weight	110g
Housing material	Glass
Installation	Wall mounting
Protection degree	IP20

Installation Steps

- Mount the wireless power interface in the wall box.
- Put this device into wireless power interface.

Important Notes

- The panel should work with wireless power interface
- Real production may be different from pictures in the right
- Touch performance - touch panel sensitivity needs to be readjusted after installation
- Installation - US wall box, wall mounting

Safety Precautions



- The screw down strength should not exceed 0.1Nm.
- Mounting position: Indoor.
- Avoid the rain or water into the module, it will damage this device.

Overviews

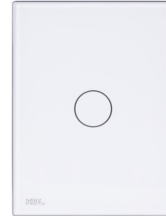

HDL-MPT1-RF.46



HDL-MPT2-RF.46

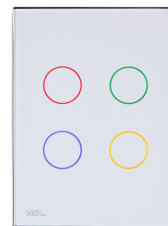

HDL-MPT4-RF.16

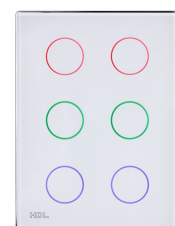

HDL-MPT6-RF.16

Wireless iTouch Series Panel US, Multi-function control panel, embedded with RGB LED backlight for each touch button, any color is available for the button via setting in HDL Bus configuration tools software. Use the wireless communication mode by wireless gateway to control target.

Functions

- Key Mode: Single on/off, Single on, Single off, Combination on, Combination off, Combination on/off, Double click single on/off, Double click combination on/off, Inching, Short/long press, Short press/long inching.
- Key Control Type: Scene, Sequence, Timer Switch, Universal switch, Single channel lighting control, Broadcast scene, Broadcast channel, Curtain Control, GPRS Control, Panel Control, Security Module, Z-audio Control, Universal Control, Link Page, DALI Area Dimmer, RGB Control, Logic Light Adjust, Logic Scene, etc.
- The wireless power interface provides the working voltage. And the panel can control four wireless power interfaces at the same time.
- Indicator intensity is adjustable.
- Supports online upgrading via HDL Buspro software tool.



Dimensions and Wiring

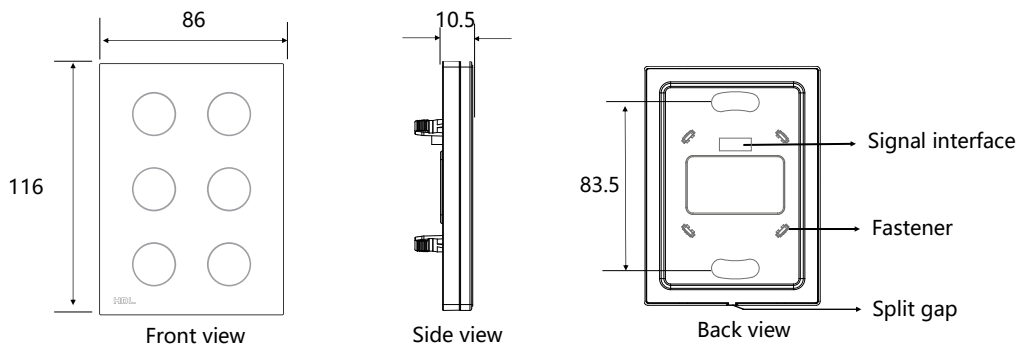

Take iTouch 6 Buttons US as an example.

Subnet ID and device ID setting: The subnet ID and device ID should be modified in the mesh gateway. Keep pressing any button for 25s, it will enter the gateway setting mode. Now, you can modify the subnet ID and device ID of the panel in the HDL Buspro Setup Tool. (It must be same as the subnet ID of mesh gateway.)

Address modification: If you want to modify, the panel should finish the gateway setup mode. Keep pressing any button for about 15S, and then all LED indicators will flash together, use HDL Buspro Setup Tool to modify the address (Address management->Modify address)

Touch button: Control targets.

Signal interface and fastener: Connect to power interface.

Split gap: Insert a slotted screwdriver to the split gap, separate the panel and power module.

Installation

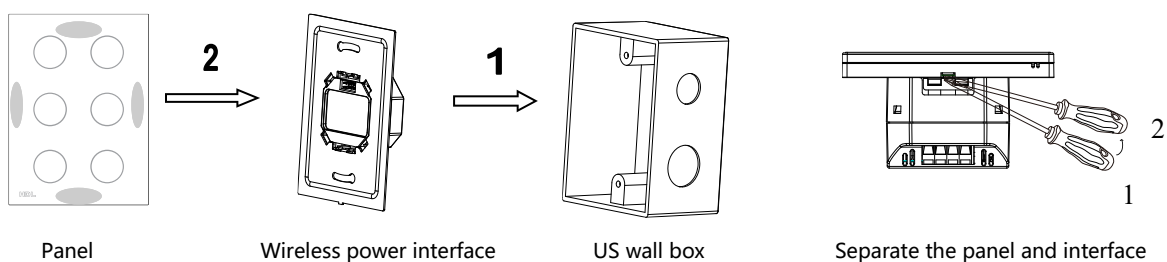

Installation: Hold the edge of panel, (shown as above), insert the power interface module vertically. Do not push the panel too hard.

Split: Insert a 2.5mm-screwdriver to the split gap, pry up from position 1 to 2, then the wiring hole will open. Then separate the panel and wireless power interface.

Wall box: For convenience of the wiring installation, the wall box should be deeper than the power interface.