

Parameters

Electrical Parameters:	
Input Voltage	AC220V±10%
Frequency	50Hz±2%
Power consumption with load	Less than 10W
Output channel	12 channel
Out current in each channel	Max. 12A
Total current in channel	Less than 120A
Connection	Three phase and five wires
Environment Conditions:	
Working temperature	0°C~45°C
Working relative humidity	< 90%
Storage temperature	-20°C~+60°C
Storage relative humidity	< 93%
Approved:	
CE	
RoHS	
Product Information:	
Dimensions	600×290×162(mm)
Weight	21.8kg
Housing material	
Installation	Wall mount
Protection degree	IP20

Installation

- **Power cable:** Phase A-Yellow 10mm² copper wire
Phase B-Green 10mm² copper wire
Phase C-Red 10mm² copper wire
- **Line:** Light blue 10mm² copper wire
- **Earth Line of Equipment:** Double-color of yellow and green 10mm² copper wire
- **Load:** 2.5mm² copper wire
- **Buspro connection:** Cat5e
- **Fire protection line:** 18AWG double core wire

Notes

- According to the total load, select the power distribution system.
- Ensure good ventilation, pay attention to damp proof, quakeproof and dustproof.
- Do not disturb the equipment and overload.
- Ensure enough power source.
- (PE) should be connected.
- Check the connection, avoid the wires has damaged.
- Contact professional maintenance staff or HDL company when Product has problem.

Overview



SB-WL-D1210 is the high performance intelligence dimmer which is a silicon controlled rectifier power output with 12 channels. Communication is HDL Buspro cable, it has scene controller and fire protection control output. In addition, it can be added the load test function according to users' requirement. It can be used in intelligence lighting, switch control and so on.

Functions

- 10Bitdimming accuracy.
- 12-channel dimming outputs.
- LED indicator status.
- Scene controller.
- Maximum 12 separate areas, each area has 99 scenes and the maximum running time is 60 minutes.
- Up to 99 sequences, each sequence has 99 steps and the time interval is 60 minutes for each step, each sequence has 4 running modes of "forward", "backward", "forward and backward" and "random".
- Low, high, max threshold for each channel.
- Each channel has emergency bypass button and debugging bypass button
- Each scene, area, sequence, channel should mark up.
 - * Each channel has current load testing.
 - * Each channel has MCB status testing.
 - * MCB switch trip warning.
 - * Bad lights warning.
- Communication: HDL Buspro
- Provides 250mA current(DC24V) for HDL Buspro.
- Fire protection switch.
- Short circuit and overload protection, earth protection.
- Remote programming and management.
- Device can be restored to previous scene or specified scene, sequence.

Note: functions with * are optional.

Dimensions and Wiring

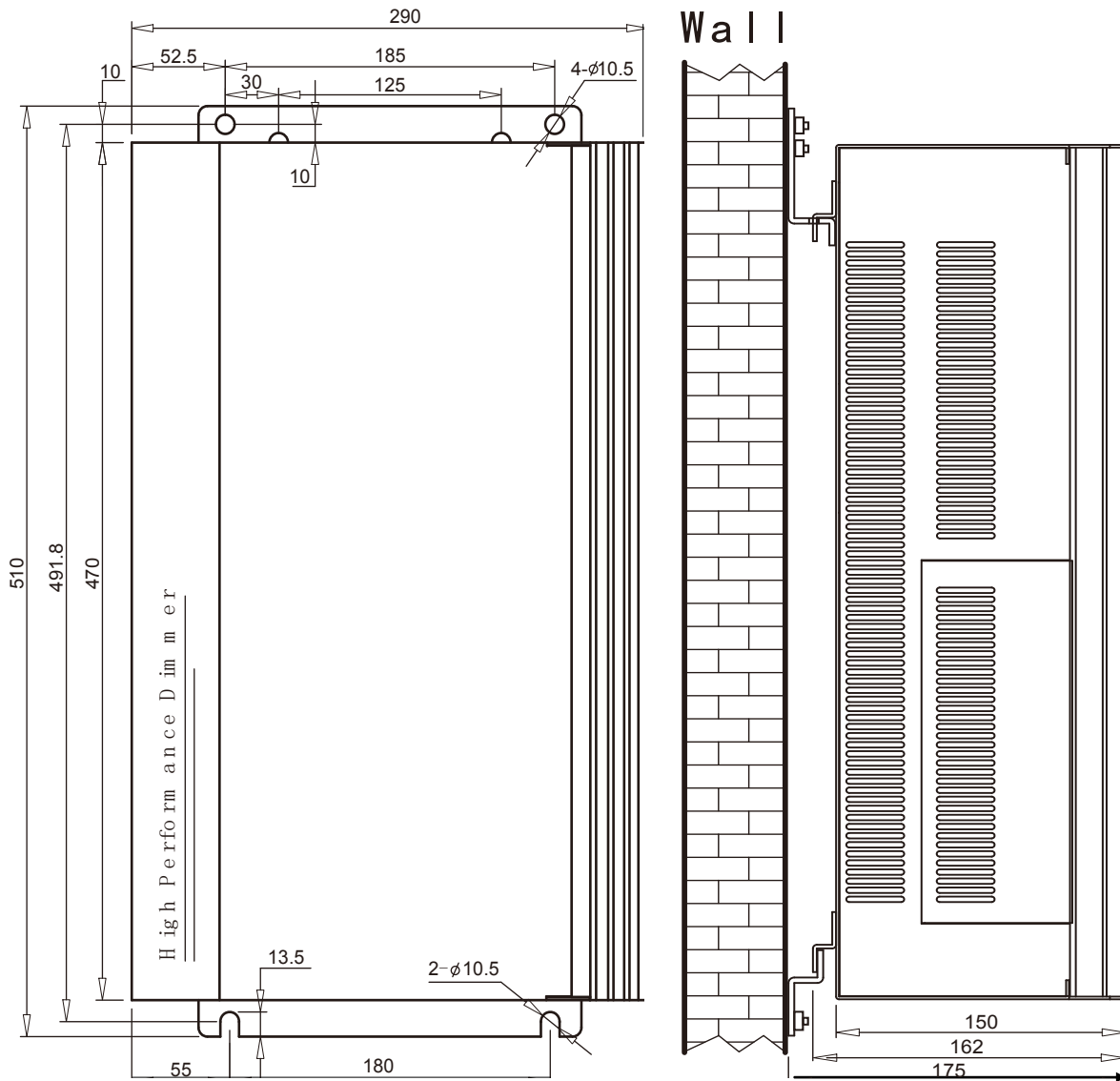

Installation dimensions

Dimensions and Wiring

- 2 cover board adsorbed magnets, it is in the inner cover board.
- Heat dissipation aluminum rod.
- Cover, it can be opened from the left side with your hand.

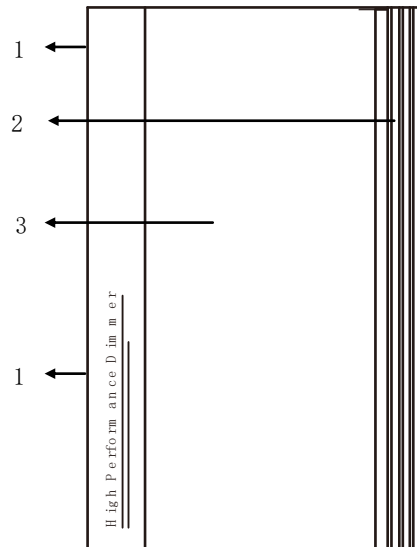

Front

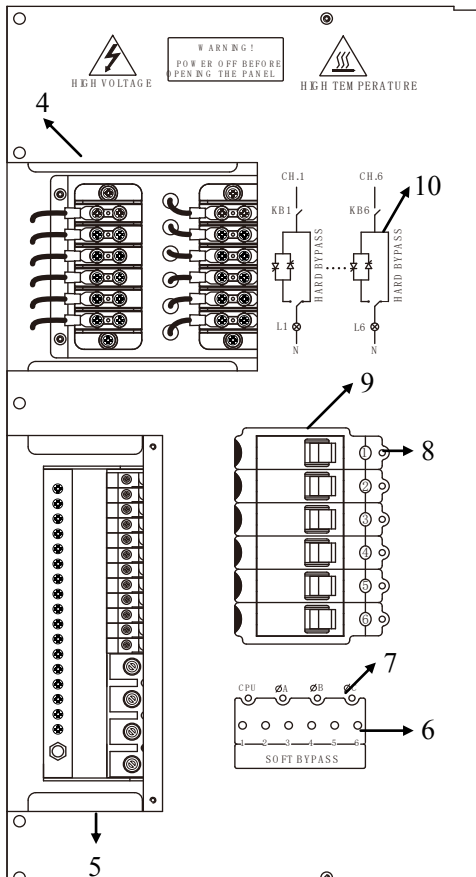

Inside

4. Cover board of jumper wiring
Shown as left, it must open the cover when is wiring.
5. Cover board of power input and load wiring
Shown as left, it must open the cover when is wiring.
6. Channel controller
Total is 12, they can control on/off of the channel 1 to 12.
7. Status indicator
From the left:
CPU indicator - On-status on, off-status off.
A phase of power indicator - On-power on, off-power off.
B phase of power indicator - On-power on, off-power off.
C phase of power indicator - On-power on, off-power off.
8. Channel output signal indicator
Total is 12, from top to button is channel 1~12.
9. Load channel switch(16A)
Total is 12, from top to button is channel 1~12. The rated current is 16A, it will be closed in a moment when over current to the load circuit to protect it
10. Connection schematic

It has two types of control: one is bypass and the other is silicon controlled rectifier. And the original is bypass

The jumper wiring terminal is under the "4 cover board of jumper wiring", open the screw of the cover board, you can find it, shown as left

There are 12 terminals and from top to bottom is channel 1(CH1), channel 2 (CH2), ...channel 12(CH12)

- 11 Jumper terminal of the silicon controlled rectifier channel
- 12 Output connection terminal
- 13 Jumper terminal of bypass

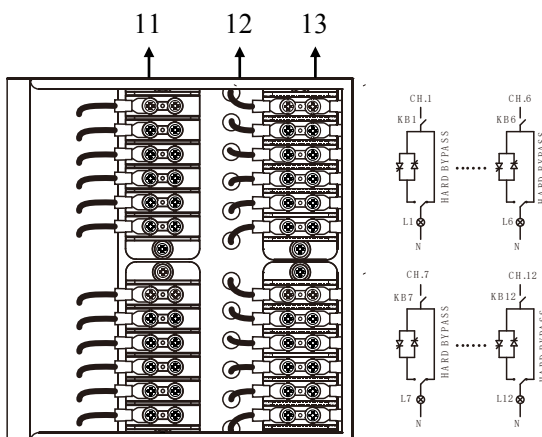

Jumper wiring terminal



Dimensions and Wiring

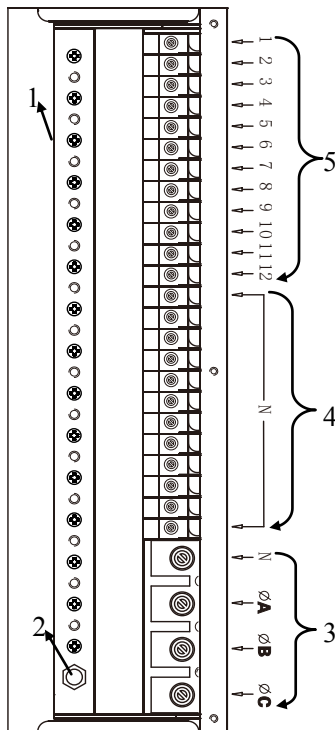

Power input and load wiring terminal

1. Load ground wiring terminal: Connect to load wiring terminal.
2. Equipment ground terminal: Connect to ground.
3. Power input socket: from top to bottom is N, phase A, phase B, phase C.
4. Null line of channel 1 to 12 wiring terminal (common terminal).
5. Live line of channel 1 to 12 wiring terminal: From top to bottom is channel 1 to 12. Relationship of channel and phase 3 input power: channel 1,4,7,10 is correspond to phase A, channel 2,5,8,11 is correspond to phase B, channel 3,6,9,12 is correspond to phase C.

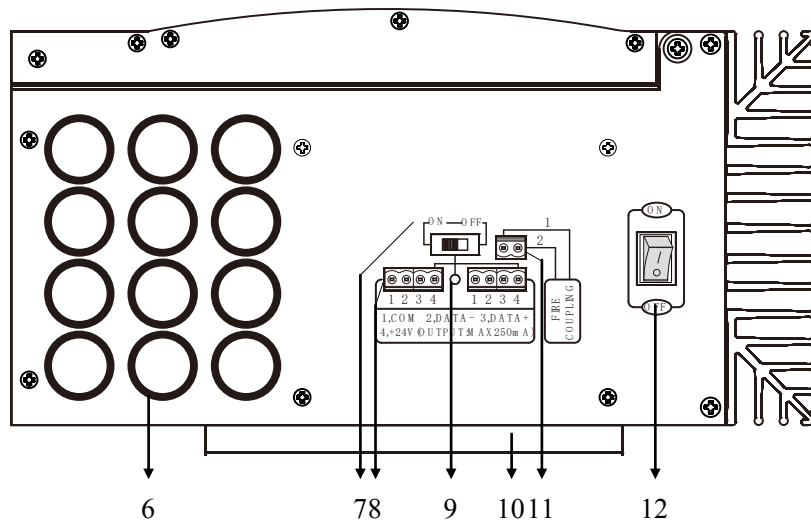

Underside

6. Wiring holes

7. The switch of +24V power output (+24V output is used in HDL Buspro cable)

8. HDL Buspro cable terminal (in two sides)

Terminal number definition: 1→COM (common port)

2→DATA- (signal -)

3→DATA+ (signal +)

4→DC24V (the max input current is 250mA)

The corresponding relation between HDL Buspro (Cat5e) and signal:

COM→brown white, orange white

DATA - →blue white, green white

DATA + →blue, green

DC24V →brown, orange

9. +24V input indicator (It will brighten when +24V is inputting)

10. Fixed bracket

11. Terminal socket of fire protection: Connect to fire protection control

12. The power switch of equipment (note: the switch is nothing to do with +24V power output)

Dimensions and wiring

Criterion requirement of multi-branch copper wire terminal

1) Ground wiring terminal

The ground terminal is fixed by the screw. It requires that the terminal should be connected to the appropriate lug and the lug must be connected to the special equipment. Shown as following picture.

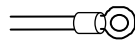

2) Other wiring terminal

The power input, live line and null line should adopt the appropriate cable sheath. The cable sheath should be connected to the special equipment. Shown as following picture

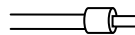

Typical system connection

The typical system connection (shown as following picture)

From the control panel (with infrared remote controller), system management server and fire protection management system, it can realize the function of dimming control, switch control, fire protection control, system management and other control system, etc.

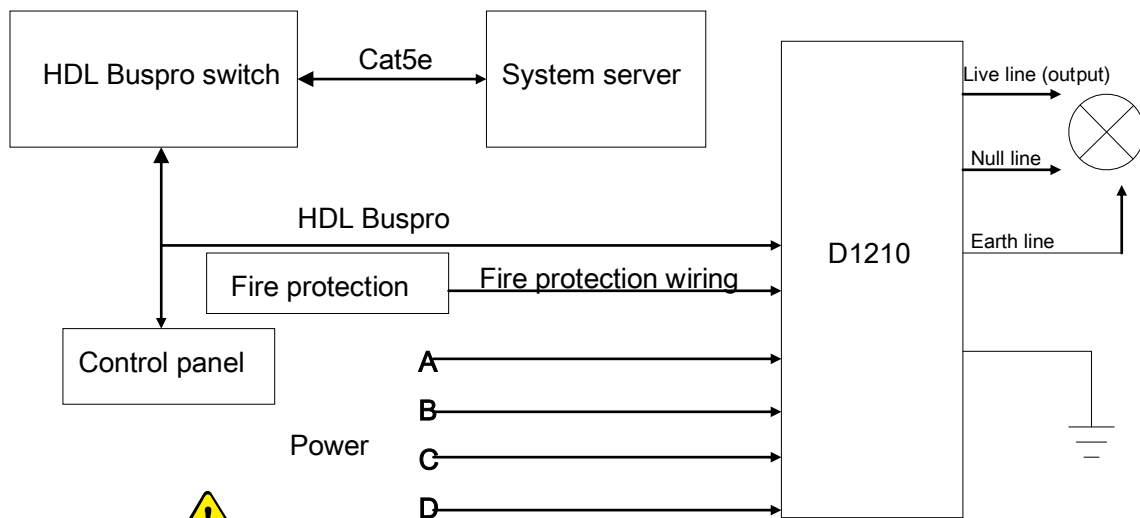

Safe Attention

- Read all instruction in detail before using.
- Do not disturb the equipment and overload.
- Ensure enough power source.
- (PE) should be connected.
- Do not make wrong connection on Buspro interface, it will damage the Buspro interface of this module.
- Do not get AC power into Buspro wire , it will damage all devices in the system.
- Avoid contact with liquids and corrosive gases.

Packing List (2PCS)

- | | |
|--|----|
| ■ Instructions | ×1 |
| ■ High Performance Intelligence Dimmer (SB-WL-D1210) | ×1 |